

SECTION N-N

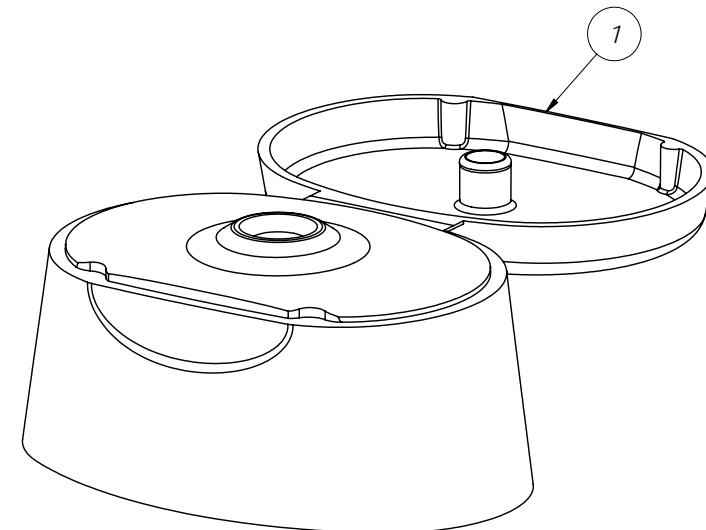
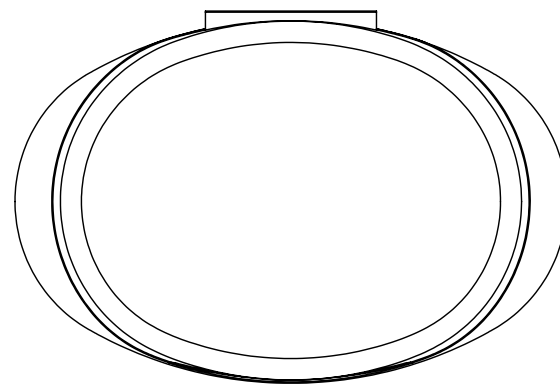
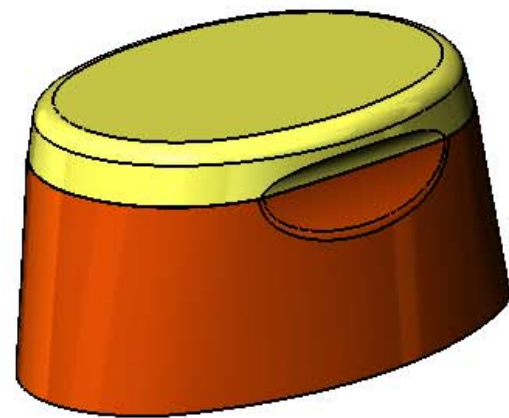
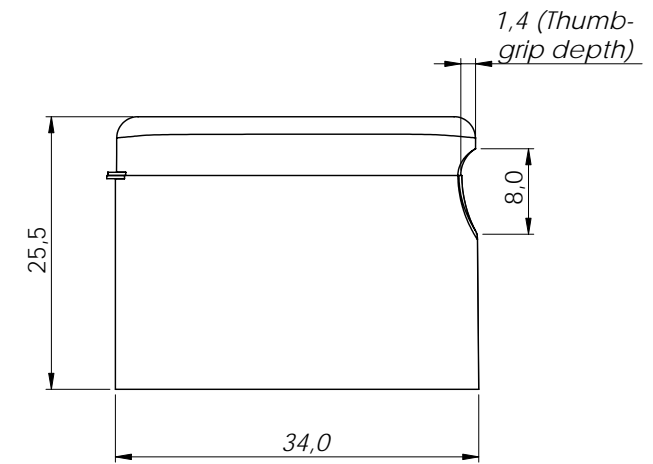
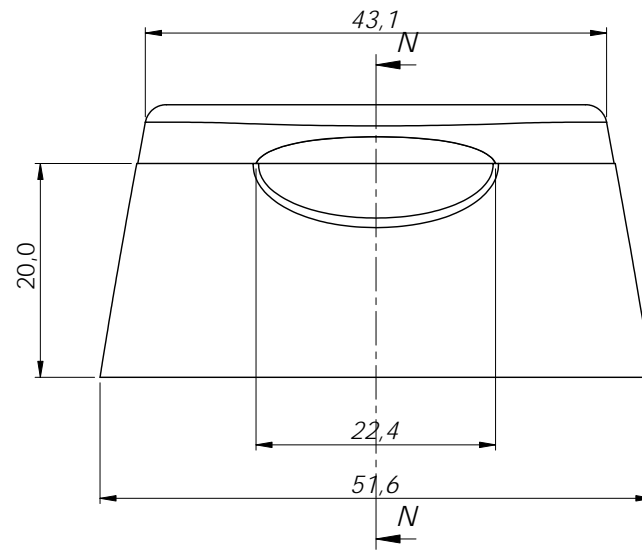

1	1	Closure Flip top	00-260	PP	5.9	
Item	Quant.	Title/Name	Art-/Mold-no	Material	Weight	Note
Designed by	Checked by	General Tolerances		Filename	Date	Scale
TB	BN	-		12190	2008-01-14	2:1
Emballator Växjöplast AB Smedjegatan 8 352 46 VÄXJÖ Tel: +46(0)470 722000 Fax: +46(0)470 722001			Title/Name Closure Flip Top			
			Standard			
			Drawing number 12190		Rev.no -	Sheet 3/3