

This document may not be duplicated without our written permission and its content not exposed to any third party neither be used for any unauthorized purpose.
 Denna handling får inte kopieras utan vårt skriftliga medgivande och dess innehåll får inte yppas för tredje man och inte heller användas för något obehörigt ändamål.

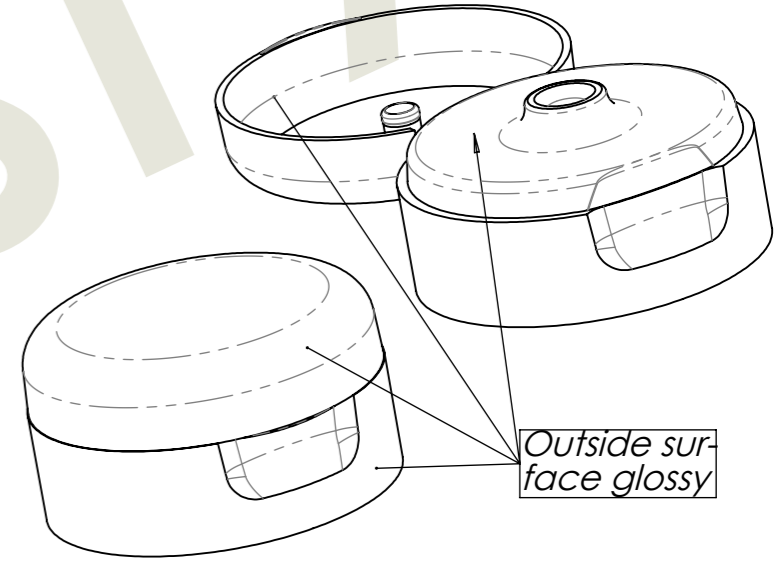
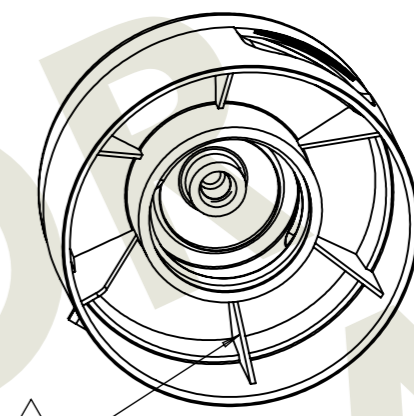
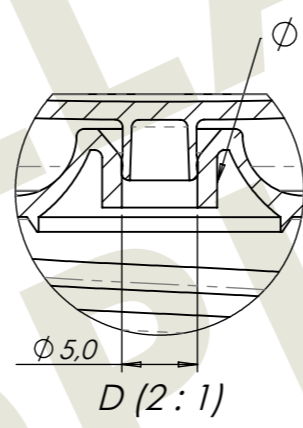
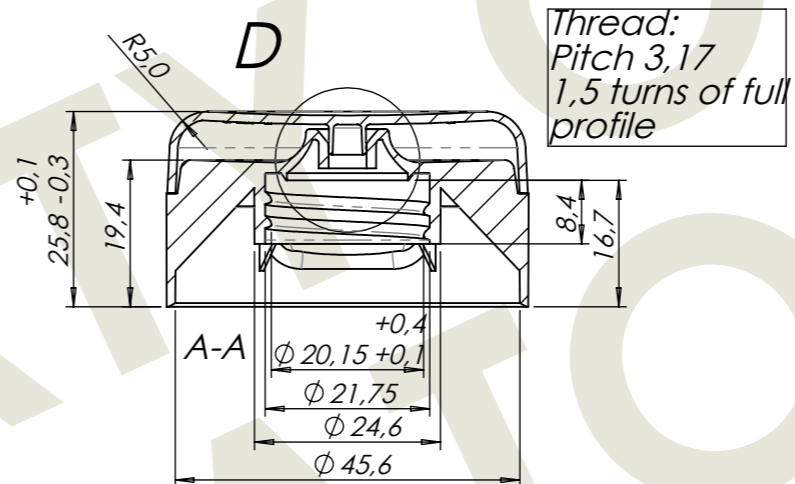
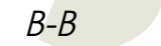
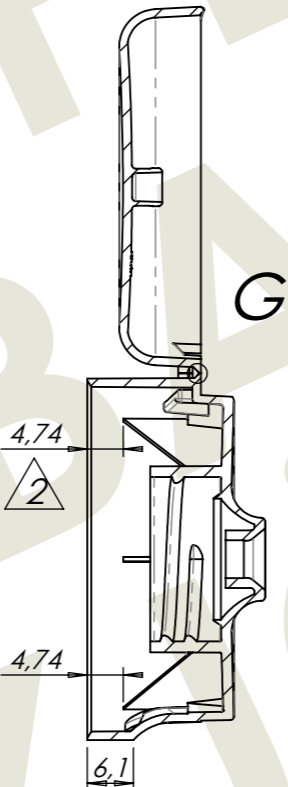
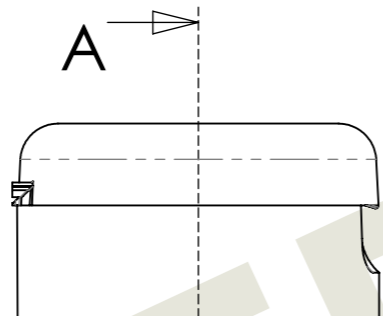
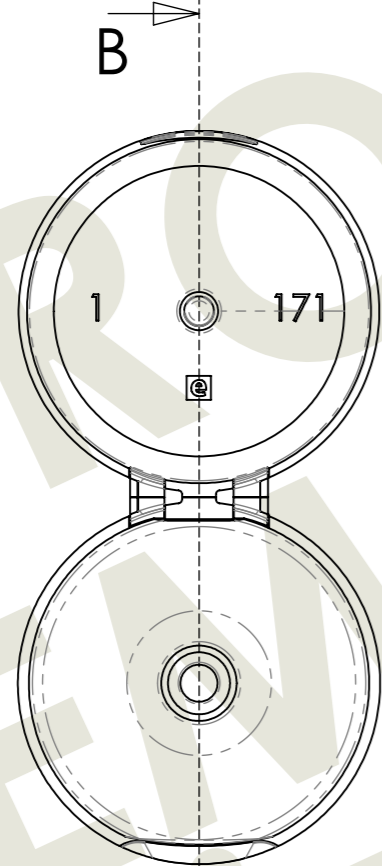
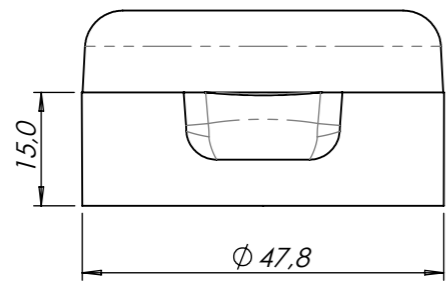
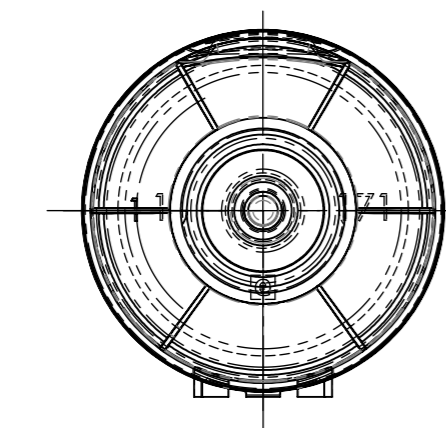

REVISIONS					
Edition	Rev.no	Revision note	Date	Ini.	Appr.
A	1	6xribs rearranged (Not Implemented)	2012-10-18	TB	BN
B	2	Height rib was 3,0	2014-04-01	TB	BN

1	1	22mm Closure	22-171	PP	9,0g	
Item	Qty.	Title/Name	Art.No.	Material	Weight	Note
Designed by	Checked by	General Tolerances		Filename	Date	Scale
TB	BN	±0,2		S 22-171-5mm B	2001-11-08	1:1
Emballator Växjöplast AB Smedjegatan 8 352 46 VÄXJÖ Tel:+46(0)470 722000 Fax:+46(0)470 722001			Title/Name 50mm EH Softline Art.No. 22-171/5			
Drawing number S 22-171-5mm B				Rev.no	Sheet	
				B	1/1	