

This document may not be duplicated without our written permission and its content not exposed to any third part neither be used for any unauthorized purpose.
 Denna handling får inte kopieras utan vårt skriftliga medgivande och dess innehåll får inte yppas för tredje man och inte heller användas för något obehörigt ändamål.

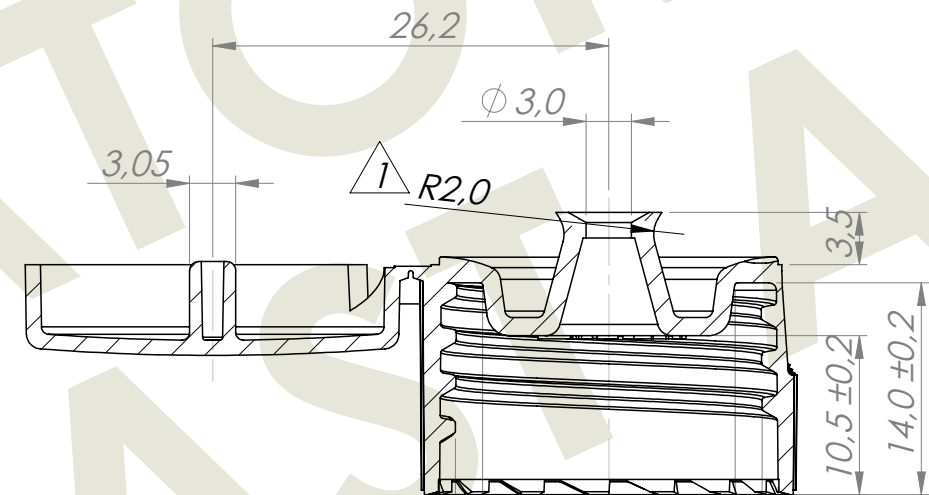

SECTION A-A

- $\phi 16,7 \pm 0,2$
- $\phi 20,20 \pm 0,2$
- $\phi 22,30 \pm 0,2$

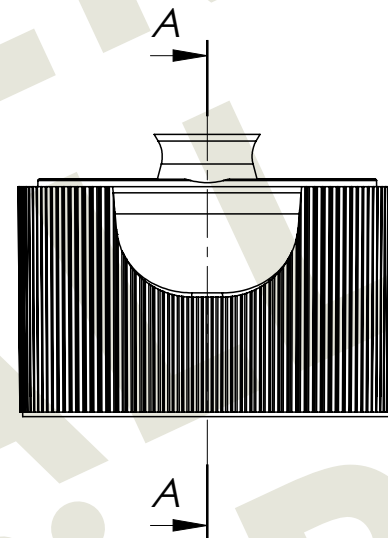
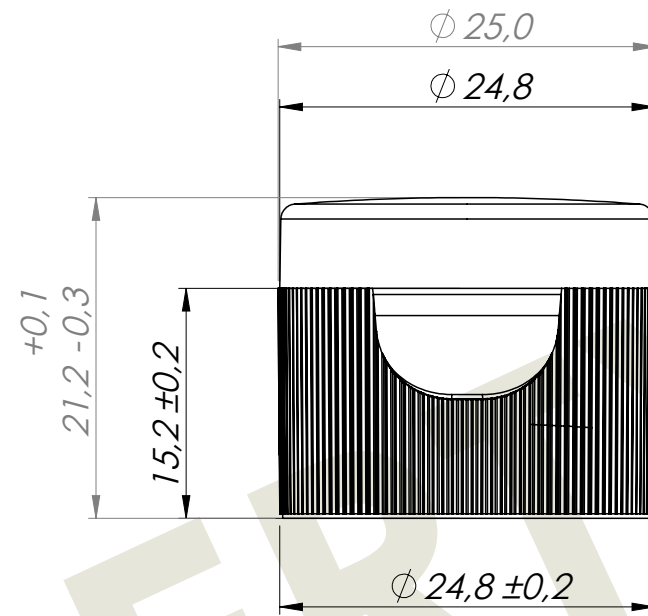
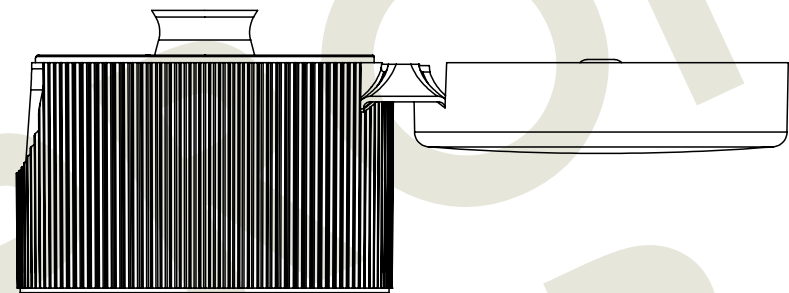
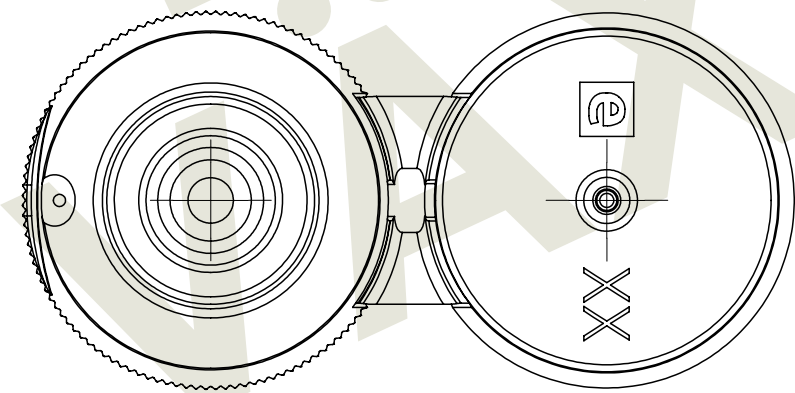
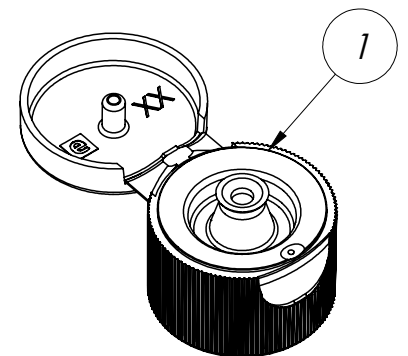

Thread:
 One entrance.
 Pitch 3,0mm.

Item	Qty.	Title/Name	Art.No.	Material	Weight	Note
1	1	Closure 22mm	22-247	COP	2.9	-

Designed by TB	Checked by BN	General Tolerances -		Filename 12156A	Date 2007-10-11	Scale 2:1	A3	
Emballator Växjöplast AB Smedjegatan 8 352 46 VÄXJÖ Tel: +46(0)470 722000 Fax: +46(0)470 722001			Title/Name Closure 22mm Flip top Standard		Drawing number S 22-247		Edition A	Sheet 2/3

REVISIONS					
Edition	Rev.no	Revision note	Date	Ini.	Appr.
A	1	Radius in product was 1,0mm	2014-08-13	TB	BN