

This document may not be duplicated without our written permission and its content not exposed to any third part neither be used for any unauthorized purpose.  
 Denna handling får inte kopieras utan vårt skriftliga medgivande och dess innehåll får inte yppas för tredje man och inte heller användas för något obehörigt ändamål.

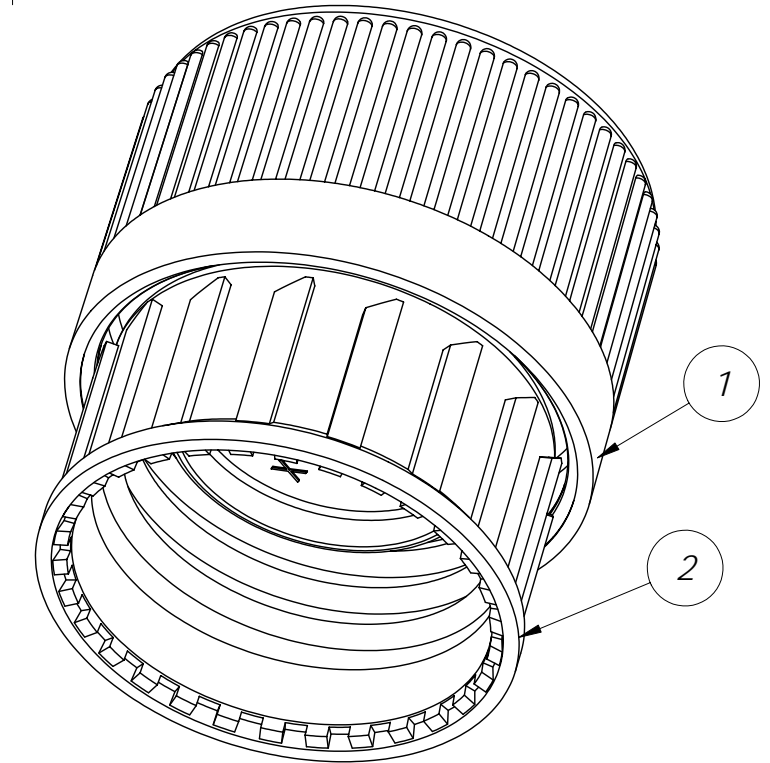
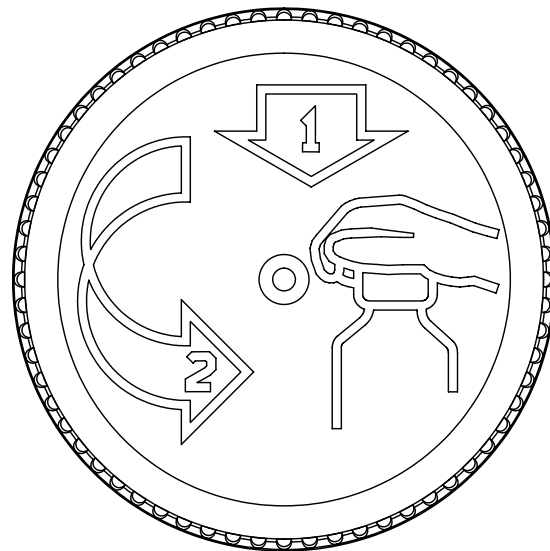
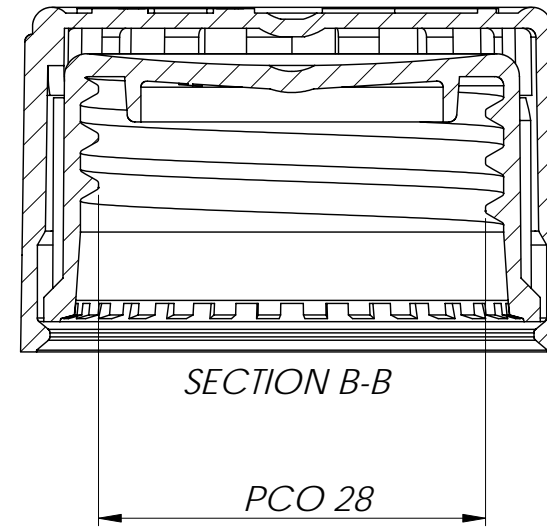
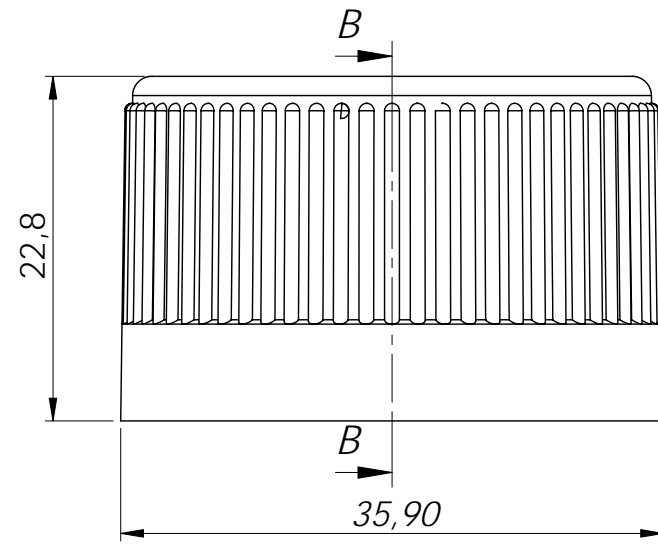

2	1	Closure 28mm BS	28-944	PP,POM		
1	1	Cover	00-127	PP		
<b>Item</b>	<b>Quant.</b>	<b>Title/Name</b>	<b>Art-/Mold-no</b>	<b>Material</b>	<b>Weight</b>	<b>Note</b>
Designed by TB	Checked by BN	General Tolerances -		Filename 12210	Date 2008-05-14	Scale 2:1
<b>Emballator Växjöplast AB</b> Smedjegatan 8 352 46 VÄXJÖ Tel:+46(0)470 722000 Fax:+46(0)470 722001			Title/Name Ass'y 28-944/00-127			
			Drawing number 12210			Rev.no -
Standard						