

Thread:
 For neck P40.
 One start RH
 Pitch: 4,0

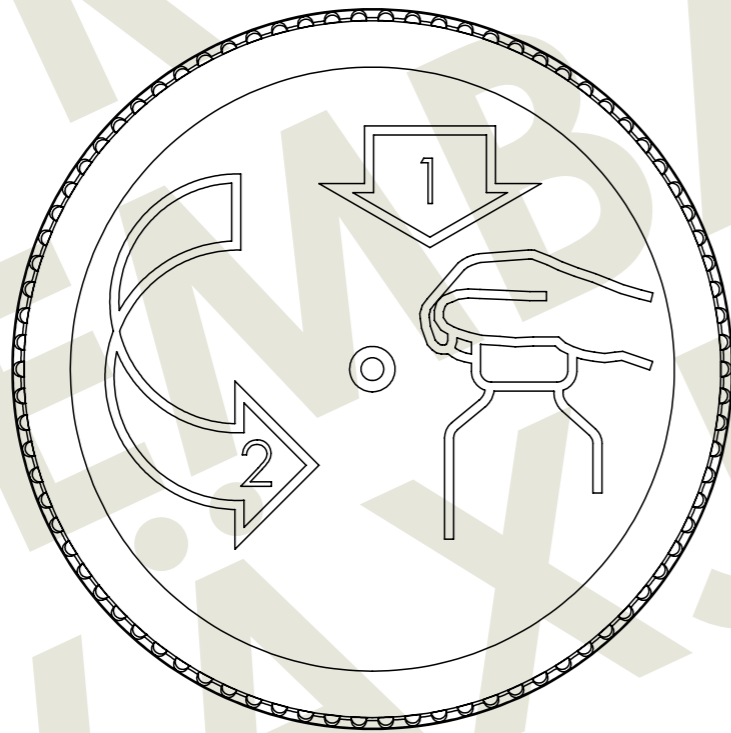
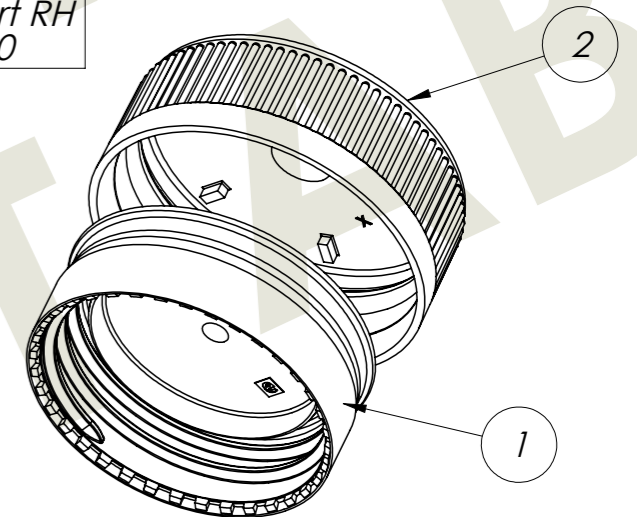

UNREGISTERED COPY

Item	Qty.	Title/Name	Art.No.	Material	Weight	Note
2	1	Cover	00-901F	HDPE	6.2	-
1	1	Closure	40-948	HDPE	5.6	-

Designed by TB	Checked by AH	General Tolerances -		Filename 12443A	Date 2013-06-07	Scale 1:1
Emballator Växjöplast AB Smedjegatan 8 352 46 VÄXJÖ Tel: +46(0)470 722000 Fax: +46(0)470 722001			Title/Name Ass'y 40-948BS/00-901F 40mm Child res. closure Standard			
Drawing number S 40-948BS_00-901F					Edition A	Sheet 2/2