

This document may not be duplicated without our written permission and its content not exposed to any third party neither be used for any unauthorized purpose. Denna handling får inte kopieras utan vårt skriftliga medgivande och dess innehåll får inte yppas för tredje man och inte heller användas för något obehörigt ändamål.

For measures without tolerance	
No decimal	±0,2
One decimal	±0,1
Two decimals	±0,01
Three decimals	±0,005

Thread:  
One start. RH.  
Pitch: 3,63mm

Inside draft is  
0,3° per side

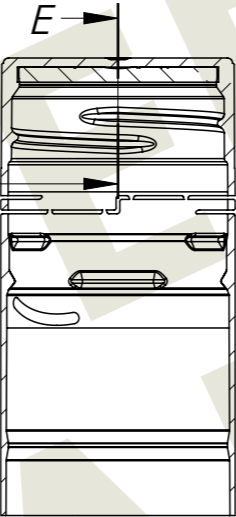
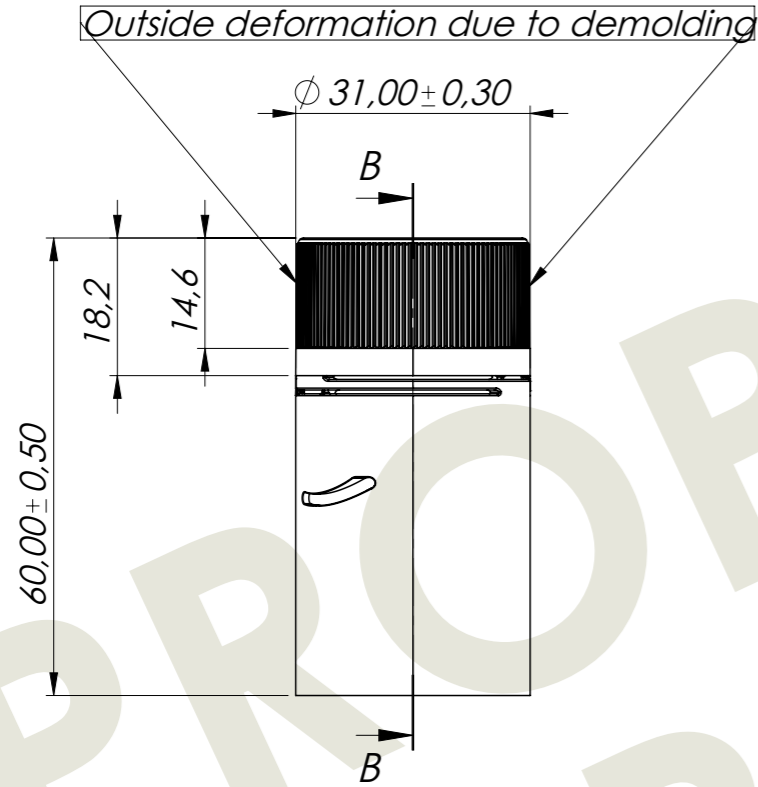

SECTION B-B

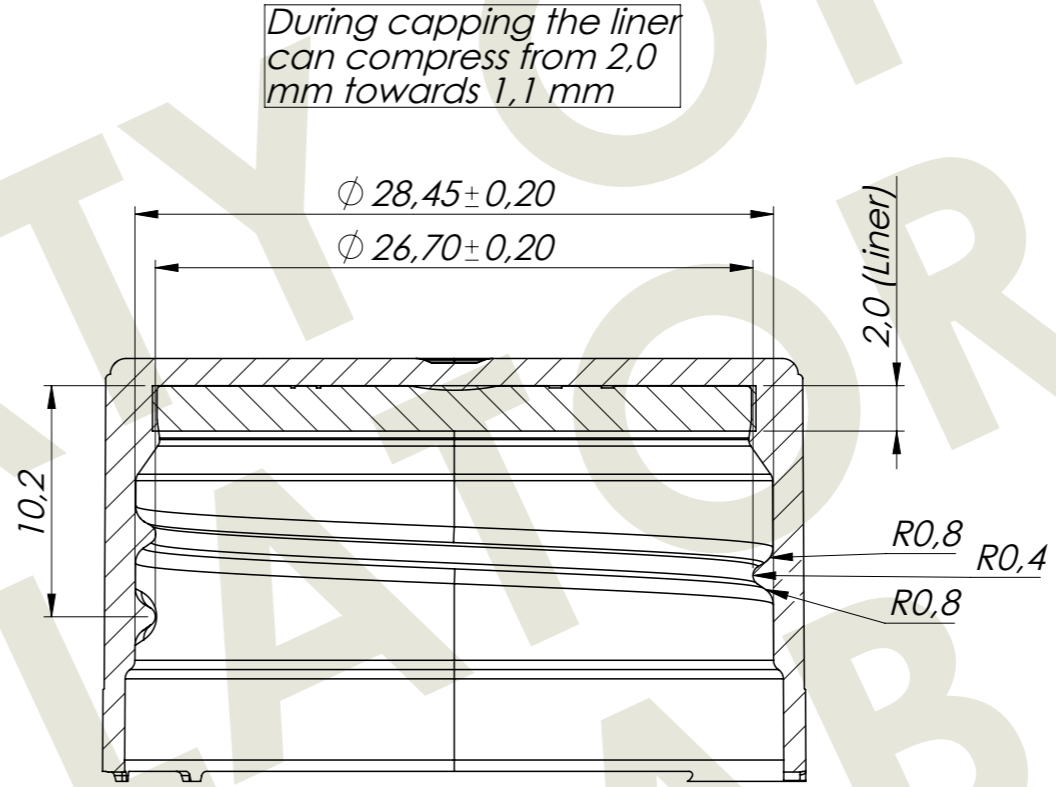

SECTION E-E  
SCALE 3 : 1

During capping the liner  
can compress from 2,0  
mm towards 1,1 mm

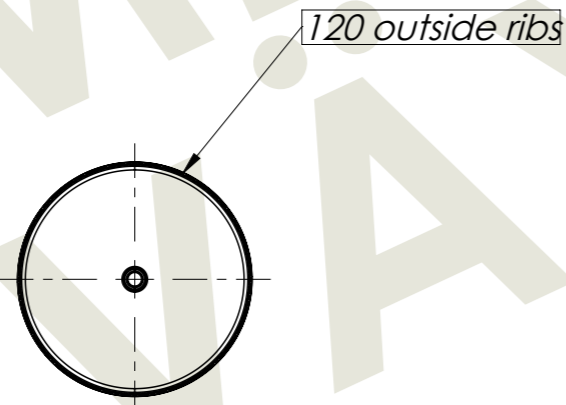
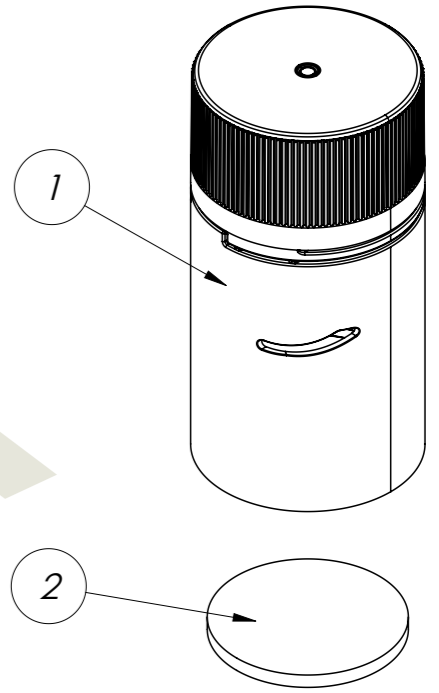

Item	Qty.	Title/Name	Art.No.	Material	Note	
1	1	Wine Cap 30H60	28-409A	HDPE	-	
2	1	Liner	Saranex ALKOzell 26,55x2,00	EPE		
Designed by EKA		Checked by BNI	General Tolerances SS-ISO 2768-1 m	Filename 12790A	Date 2024-01-03	Scale 1:1

**emballator**  
Packaging solutions for future generations

Title/Name Wine cap 30H60 Saranex Liner	
Drawing number S 28-409	Edition A
Sheet 1/1	